



BLENDER #37



Internationally
patented models



A kitchen Blender silent and powerful

Adapted to intensive use thanks to its powerful and silent commercial motor, it mixes all kind of hot and cold preparations.

Its new highly resistant blades crush quickly hard ingredients (ice cubes, lobster carcass...).

Its speed variation will allow you to obtain an optimal result while remaining silent.

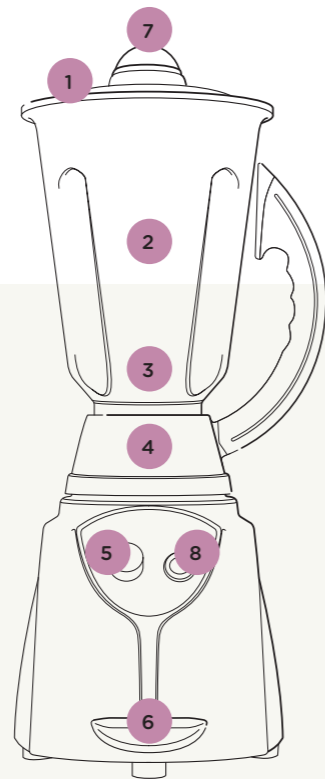

- 1 **Exclusive patent** : Santosafe® locking system for bowl and cover. Hands free use.
- 2 2L ou 4L bowls, stainless steel or transparent (without bisphénol A)
- 3 **Very resistant blades** offering a high quality blending and a better vortex. Knife assembly is ball bearings mounted.
- 4 Silent and durable coupling system kit **for intensive use**
- 5 On / Off rotary button.
- 6 Handle to open and close **Santosafe® locking system**
- 7 Removable lid (ø 46 mm) to add ingredients **while blending**
- 8 **Pulse** : 18 000 rpm

A complete range of bowls for all uses



Choose the speed according to your preparations

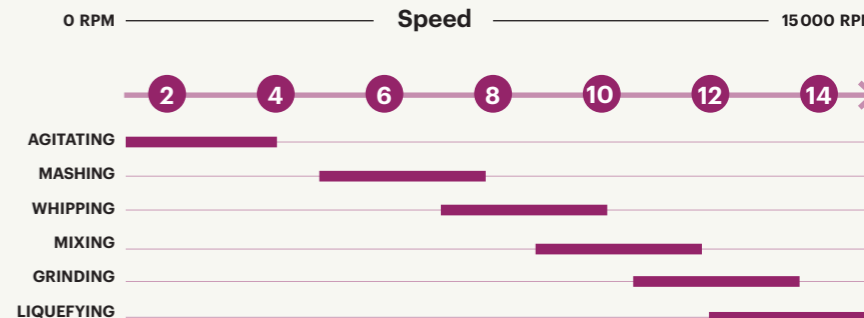

Safety, Standards, Hygiene

In accordance with the following regulations	Machinery directive 2006 / 42 / EC Electromagnetic compatibility 2014 / 30 / EU "Low voltage" directive 2014 / 35 / EU RoHS directive 2011 / 65 / EU Regulation 1935 / 2004 / EC (contact with food) Regulation 10 / 2011 / EU (Plastic in contact with food)
Harmonized European Standards	EN ISO 12100 : 2010 EN 60204-1 + A1: 2009 EN 60335-2-64 :2004 Commercial electric kitchen machines CE Marking
Electrical safety	All mechanical parts are ground connected Appliances are 100% tested after assembly
Thermal Safety	Motor protected by internal thermal detector
Acoustic Safety	Silent and powerful motor
Hygiene	All removables parts can be put in a dishwasher or easily cleaned with hot soapy water

Technical specifications

Motor
Single phase :
220-240 V - 50/60 HzV - 600 W – CE
100-120 V - 50/60 Hz - 650 W – CE, UL

Speed :
1 500 rpm (50Hz)
1 800 rpm (60 Hz)

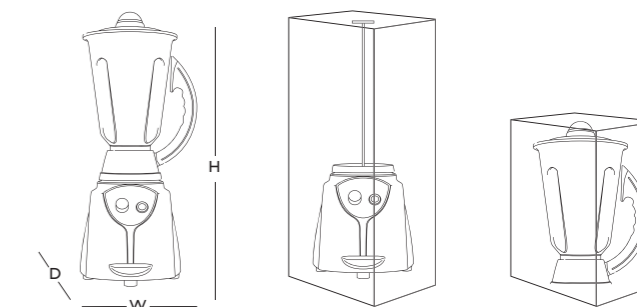

Appliance	Shipping box	Shipping box
D : 310 mm (12") W : 210 mm (8") H : 560 mm (22")	D : 400 mm (16") W : 280 mm (11") H : 650 mm (26")	D : 240 mm (9") W : 360 mm (14") H : 220 mm (9")
Weight: 8,96 kg (19,75lbs)	Weight: 10,6Kg (23,37lbs)	

PRODUCT: 2 YEAR WARRANTY | MOTOR: 5 YEARS

SANTOS KITCHEN BLENDER #37

From date 11:2019
from serial number: 1123829

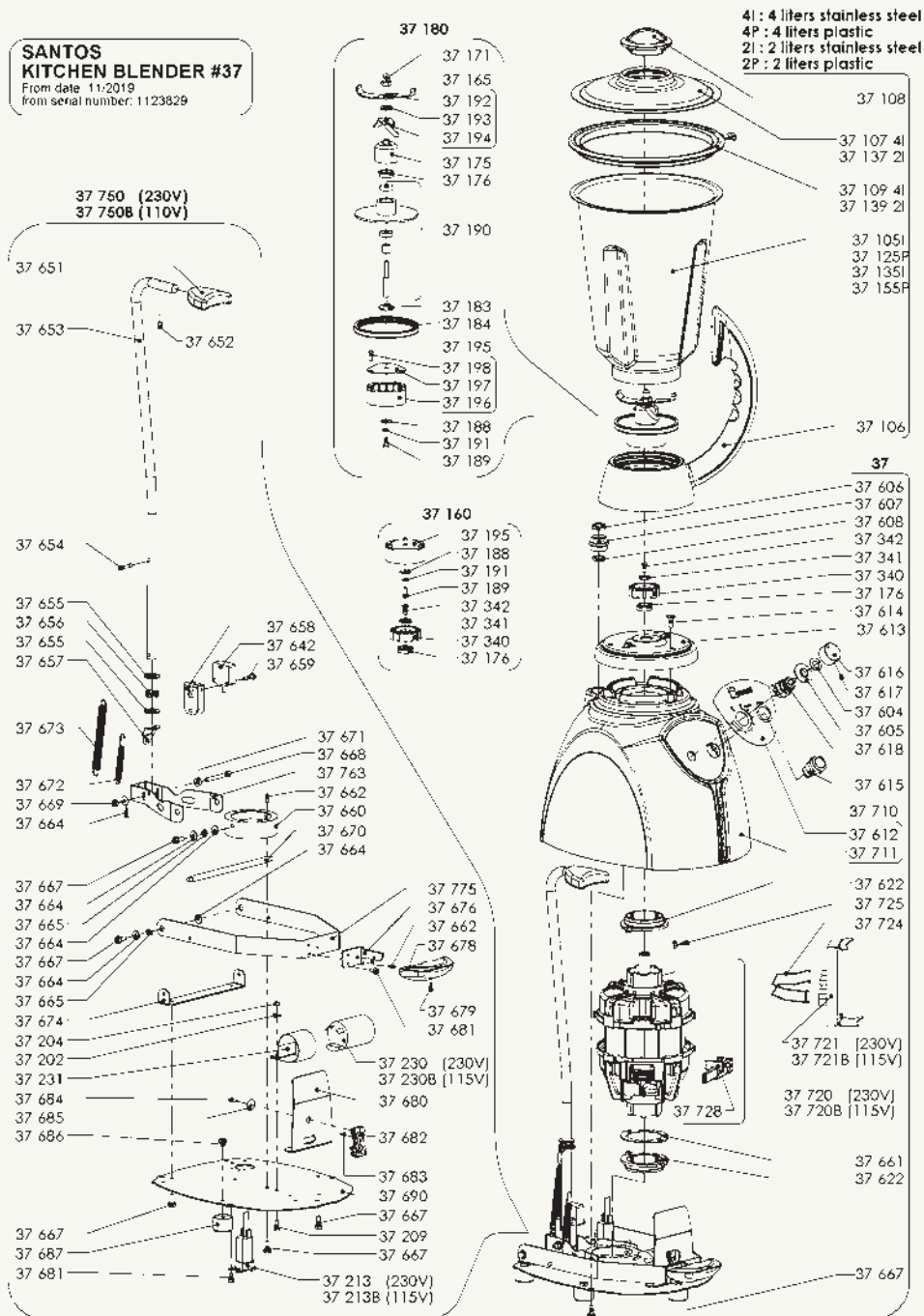

SANTOS

140-150 avenue Roger Salengro
BP 80 067
69511 Vaulx-en-Velin Cedex (Lyon) FRANCE

Tél : +33 472 37 35 29
Fax : +33 478 26 58 21
Email : santos@santos.fr
www.santos.fr

Follow us on [#santosaddict](#)
social networks

